

## Chapter 4

### Piezoelectricity Aspects

#### Detailed contents

	Page Nos.
4.1 Definition	72
4.2 Piezo Applications	74
4.3 Terms and Relationships	76
4.3.1 Polarization and charge coefficients	76
4.3.2 Piezoelectric charge coefficient (d constant)	77
4.3.3 Piezoelectric Voltage coefficient (g constant)	78
4.3.4 Relative Dielectric Constant	78
4.3.5 Relationship Between g and d coefficients	79
4.3.6 Coupling Coefficients	79
4.3.7 Young's Modulus	80
4.3.8 Dissipation Factor or $\tan \delta$	80
4.3.9 Curie Point	80
4.3.10 Aging Rate	80
4.3.11 Mechanical Quality Factor ( $Q_m$ )	81
4.3.12 Frequency Constants	81
4.4 Calculations of values for coupling coefficients	83
4.5 Vibrational Modes in Common Transducer Configurations	90

# Piezoelectricity Aspects

The Piezoelectricity aspects w.r.t the transcripts which describe the transverse direction, axial direction & shear axes are covered in this chapter.

## 4.1 Definition

Piezoelectricity from the Greek word "piezo" means pressure electricity. It is the property of certain crystalline substances to generate electrical charges on the application of mechanical stress. This is called forward piezo effect. Conversely, if the crystal is placed in an electric field, it will experience a mechanical strain. All engineering applications mostly make use of this reverse piezo effect. Such materials are useful as transducer elements for transducing electrical energy into mechanical energy and vice versa. When an AC voltage is applied, it will cause it to vibrate and thus generate mechanical waves at the same frequency of the input AC field. Similarly, it would sense the input mechanical vibrations and produce the proportional charge at the matching frequency of the mechanical input.

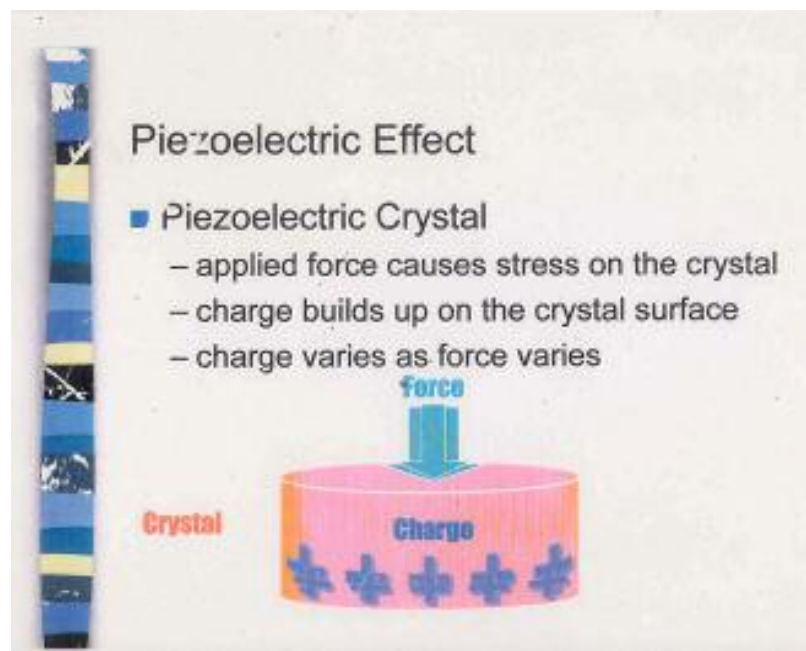

Fig. 4.1: Forward Piezoelectric Effect

Quartz is a well known single crystal material depicting such piezoelectric effects. Certain crystalline materials like that of Quartz mentioned above & Rochelle salt have piezoelectric behaviour when pressure is applied on them. A charge separation is obtained, when pressure is applied on them, within the crystal and a voltage across the crystal which is sometimes extremely high. On this principle of gas

lighter works. The popping noise of a gas lighter is due to the spring loaded hammer hitting the crystal and generating thousands of volts across the faces of the crystal. A voltage this high is identical to the voltage that drives a spark plug in a gasoline engine. Fig 4.1 shows the simple Forward piezo effect of the gas lighter. Fig 4.2 pictorially represents the forward & reverse piezo effect[183].

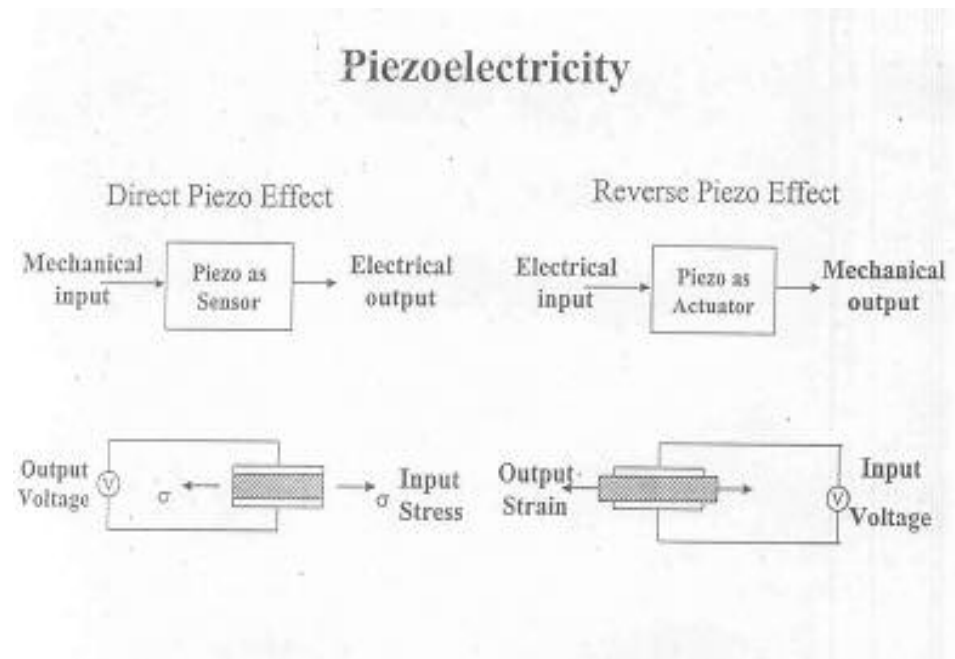

Fig. 4.2: Pictorial representation of piezo effect

Moreover, Strong piezoelectric effects can be induced in polycrystalline Lead Zirconate Titanate based ferroelectric ceramic materials. These materials are represented by the formula  $ABO_3$ , Perovskite crystalline structure wherein A-site denotes large divalent metal ion such as Pb and B-site denotes smaller tetravalent ion such as Ti or Zr. This class of ceramic materials have several advantages over single crystals including higher piezoelectric coefficients, ease of fabrication into components of any shape and size, mechanically hard and robust, chemically inert and completely unaffected by atmospheric humidity. In contrast, single crystals must be cut along certain crystallographic direction, thus limiting their possible geometrical shapes.

Sparkler manufactures piezoelectric ceramics based on the solid solutions of Lead Titanate ( $PbTiO_3$ ) and Lead Zirconate ( $PbZrO_3$ ) which are popularly known as PZT. The chemistry of  $ABO_3$  perovskite in PZT compositions permits wide modifications by way of isovalent substituents or donor dopants at A or B sites. For example, A-

sites modifications can be done by alkaline earths or rare earths cations whereas B-sites with trivalent or pentavalent cations of approximately matching ionic radii; thus allowing some tailor made properties of these class of materials. These are available in several grades, distinguished by their electrical and physical properties for well defined requirements.

## 4.2 Piezo Applications

These piezo materials are available in a variety of shapes and sizes such as disks, plates, bars, rings, rods, tubes, etc. Some of the typical applications are mentioned as follows:

- \* High Voltage Generators for gas lighters
- \* Fuses for explosives
- \* Ultrasonic cleaners
- \* Ultrasonic welders
- \* Ultrasonic atomizers
- \* Nebulizers ( a device for producing fine spray ) (Latin : nebula 'mist ' + -izer)
- \* Strain and excitation gauges
- \* Accelerometers
- \* NDT transducers.
- \* Flow meters
- \* Dynamic force and pressure measurement
- \* SONAR
- \* Deepwater hydrophones
- \* Piezoelectric actuators/translators

As part of the present investigation, the piezo patches have been used as actuators for the doubly curved reflector materials. When a piezoelectric actuator is attached to the reflector surface, the converse effects develop a bending moment in the structure making the reflector show displacements inward or outward under an electrical field.

This tip displacement of the reflector skin obtained using reverse piezo effect has been investigated at length in the chapter 8. Table 4.1 shows the relative comparison of actuation from different options of smart materials as covered in Chapters 1 & 2.

Table 4.1

Relative Comparisons – Ten Actuator Methods

Sr. No.	Method	Efficiency	Speed	Power Density
1.	Electromagnetic	High	Fast	High
2.	Electrostatic	Very high	Fast	Low
3.	Thermomechanical	Very high	Medium	Medium
4.	Phase Change	Very high	Medium	High
5.	Piezoelectric	Very high	Fast	High
6.	Shape Memory	Low	Medium	Very high
7.	Magnetostrictive	Medium	Fast	Very high
8.	Electrorheological	Medium	Medium	Medium
9.	Electrohydrodynamic	Medium	Medium	Low
10.	Diamagnetism	High	Fast	High

As per sr. no. 5 of Table 4.1, piezoelectric actuators give very high efficiency in actuation, and are therefore opted for the present investigation. Magnetic methods were not considered due to EMI / EMC related issues w.r.t the envisaged applications in microwave antenna domain . Lack of two-way memory training labs in the Austenite & Martensite states at Space Applications Centre was the reason for not opting for Shape Memory Alloys like Nitinol. For the chosen option of Piezoelectric patches the inward/ outward movement / bending behavior as mentioned above has been explained pictorially in Fig. 4.3 . Fig. 4.4 pictorial show symmetric & asymmetric modes of bending.

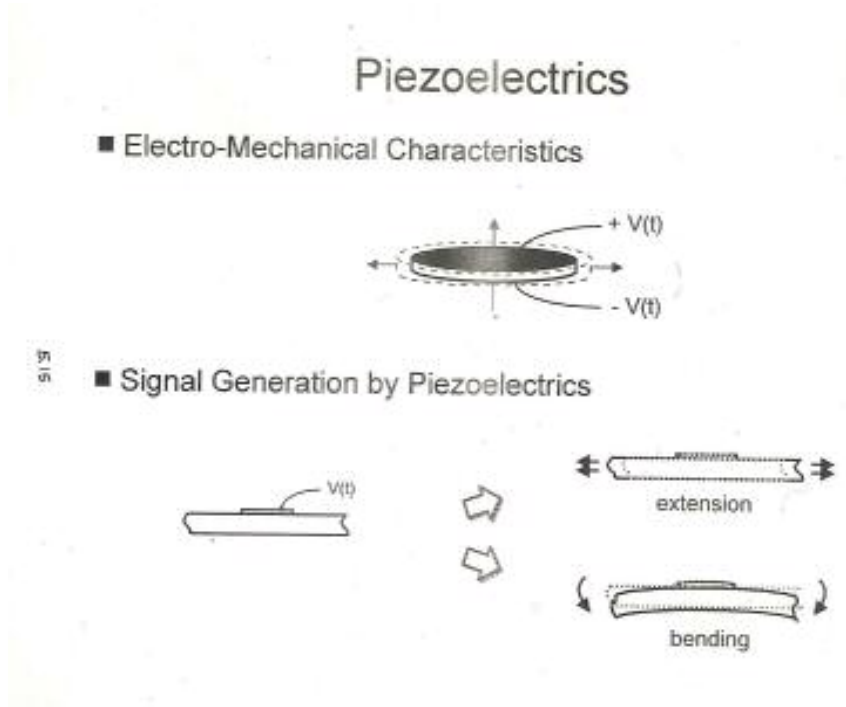

Fig 4.3 Pictorial representation of bending

## ACTIVE SENSOR: PIEZOELECTRIC MATERIALS (Sensor and Actuators)

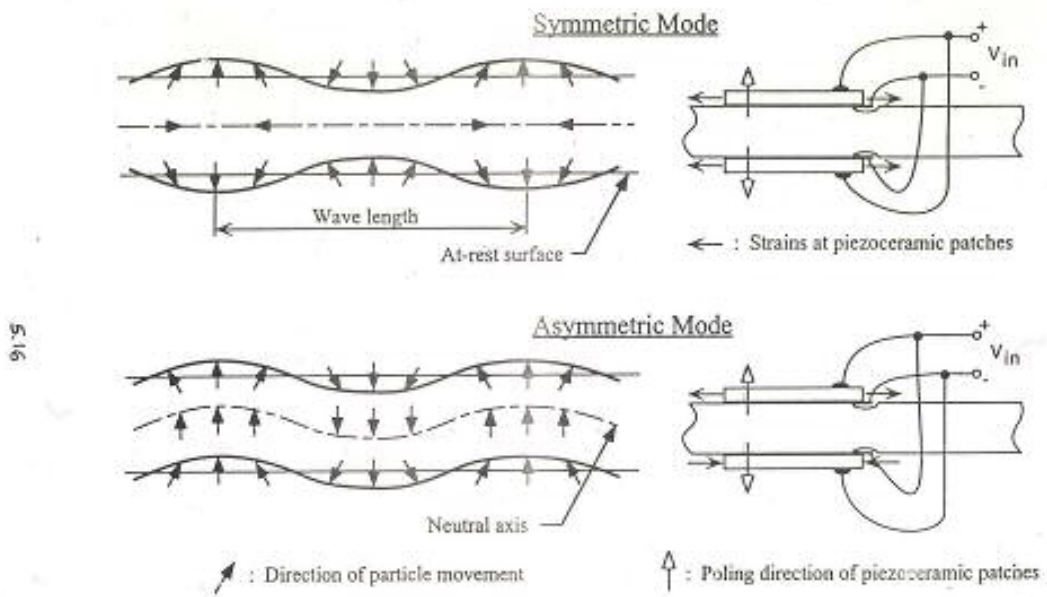
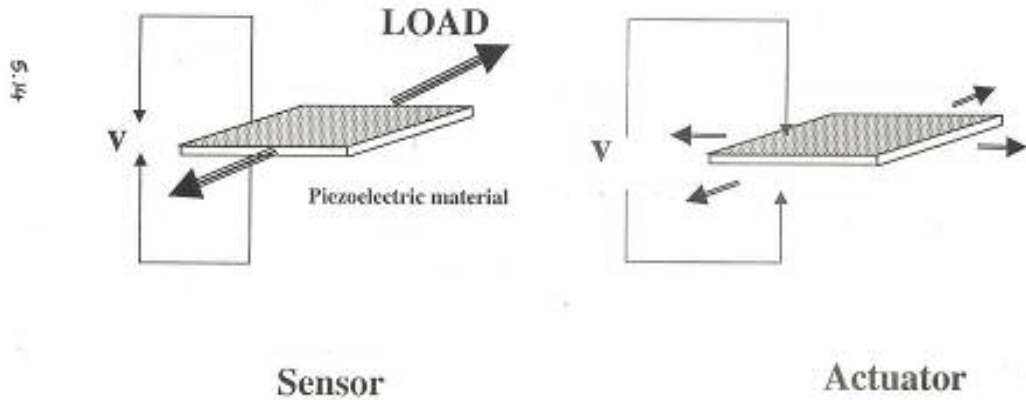

Fig. 4.4: Pictorial symmetric & asymmetric modes of bending

### 4.3 Terms and Relationships

The terms used in this field are as follows:

#### 4.3.1 Polarization and charge coefficients:

With piezoelectric ceramics, the relationship between the applied stress and the resulting responses depend upon:

- Piezoelectric properties of the ceramic.
- Size and shape of the element, and
- Direction of the electrical and mechanical vector quantities.

To identify directions in a piezoelectric element, three axes termed as 1, 2 and 3; which are analogous to the classical three dimensional orthogonal set of axes X, Y and Z are used. Material properties along the 1 and 2 axes are identical to each other but different from those along the 3 axis. For maintaining simplicity, references are made only to the 3 and 1 directions. The poling or 3 -axis is invariably taken parallel to the direction of polarisation within the ceramic as shown in Fig 4.5. The polar axis is induced during the manufacturing process by treatment with a high voltage DC field applied between the pair of electroded faces to align the domains of the material in the direction of the field.

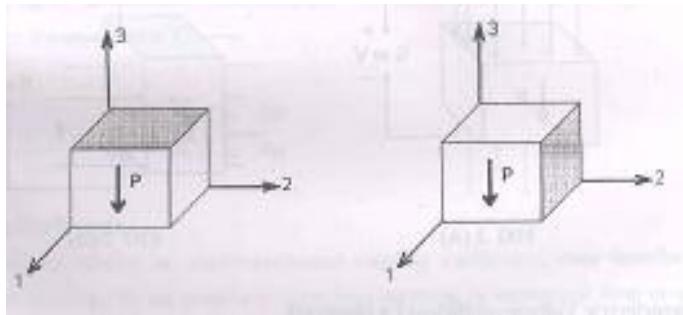

Fig. 4.5: The poling axis or 3 axis is parallel to direction of poling

The polarization vector P is represented by an arrow pointing from the positive to the negative poling electrode. In shear mode operations, the poling electrodes are later removed and replaced by a set of electrodes on the second pair of the faces. The 3-axis is not altered, but it becomes parallel to the new electrode faces as seen on the finished element Fig 4.5.

#### 4.3.2 Piezoelectric charge coefficient (d constant):

The piezoelectric d constant is a measure of the charge density per unit stress or the strain per unit field,

$$d_{ik} = (\text{Coulombs/meter}^2) / (\text{Newtons/meter}^2) \\ = \text{Coulombs / Newton}$$

$$d_{ik} = (\text{meter/meter}) / (\text{volt/meter}) \\ = \text{meter / volt}$$

Piezoelectric coefficients with double subscripts link electrical and mechanical quantities. The first subscript gives the direction of the electrical field associated

with the voltage applied or the charge or the voltage produced. The second subscript gives the direction of mechanical stress or the strain.

The piezoelectric charge coefficient  $d_{33}$  applies when the force in the 3-direction (along the polarisation axis) and is impressed on the same surface on which the charge is collected Fig 4.6, whereas  $d_{31}$  applies when the charge is collected on the same surface as before but force is applied at right angles to the poling axis.

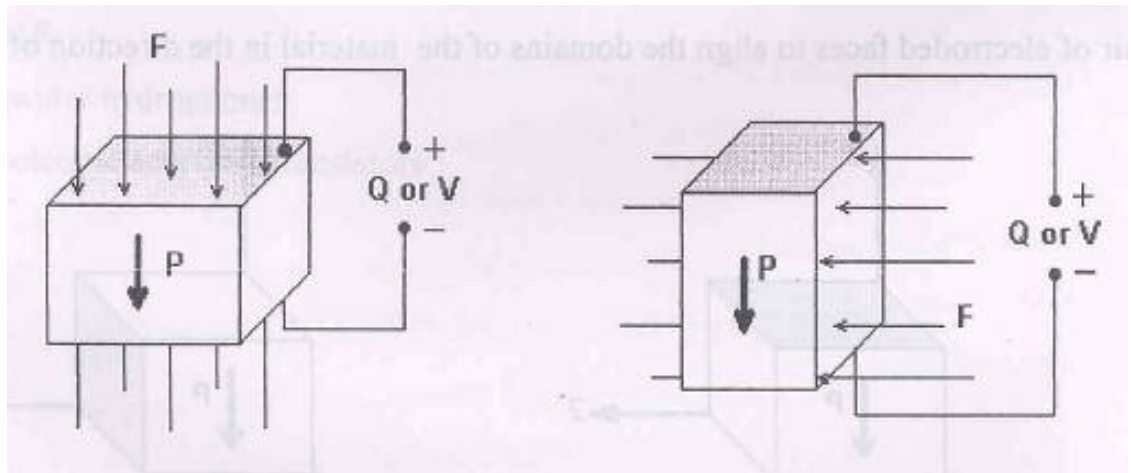

Fig.4.6: Explanation of Piezoelectric Charge coefficient

#### 4.3.3 Piezoelectric Voltage coefficient ( g constant):

The g coefficient is a measure of the field per unit stress or strain per unit charge density.

$$\begin{aligned}
 g_{ik} &= \text{Volt/meter} / \text{Newton/meter}^2 \\
 &= \text{Volt - meter} / \text{Newton} \\
 g_{ik} &= ( \text{meter/meter} ) / ( \text{Coulombs/meter}^2 ) \\
 &= \text{meter}^2 / \text{Coulomb}
 \end{aligned}$$

Output voltage is applied by multiplying the calculated electric field by the thickness of the ceramic between the electrodes. The first subscript indicates the direction of the generated voltage and the second indicates the direction of the force. A "33" subscript signifies that the electrical field generated and the mechanical stress are both along the polarisation Fig 4.6. A "31" subscript signifies that the pressure is applied at right angles to the polarisation axis but the voltage appears on the same electrodes as in the "33" Fig 4.6.

#### 4.3.4 Relative Dielectric Constant:

$K_3^T$  expresses the relative dielectric constant of the material relative to that of vacuum in the 3 direction. Multiplying this by  $\epsilon_0$ , the dielectric constant of free

space yields the absolute dielectric constant ( $\epsilon_0 = 8.85 \times 10^{-12}$  farads/meter). The superscript T applies to the mechanically free condition.  $K_3^T$  therefore, expresses the relative dielectric constant measured in the polar direction under mechanically free condition. It is generally measured at 1 kHz, well below the mechanical resonance of the specimen.

#### 4.3.5 Relationship Between g and d coefficients:

At frequencies far from resonance effects, piezoelectric ceramic transducers are fundamentally capacitors. Consequently, the voltage coefficient  $g_{ik}$  are related to the charge coefficient  $d_{ik}$  by the dielectric constant  $K_i$ , as in a capacitor the voltage V is related to charge Q by the capacitance C.

$$Q = C.V$$

$$d_{33} = K_3^T \cdot \epsilon_0 \cdot g_{33}$$

$$d_{31} = K_3^T \cdot \epsilon_0 \cdot d_{31}$$

#### 4.3.6 Coupling Coefficients:

Sometimes also referred as electromechanical coupling coefficients, these describe the conversion of energy by the ceramic element from electrical to mechanical form or vice-versa.

$$K = ( \text{Mechanical Energy stored} ) / ( \text{Electrical Energy applied} )$$

$$K = ( \text{Electrical Energy stored} ) / ( \text{Mechanical Energy applied} )$$

Subscripts denote the relative directions of the electrical and mechanical quantities and the kind of motion involved.  $k_p$  signifies the coupling in a thin round disc polarized in radial expansion and contraction, whereas  $k_{33}$  is appropriate for a long thin bar or rod, electroded on the ends, poled lengthwise and vibrating in simple length expansion or contraction.  $k_{31}$  relates to a thin long bar, electroded on a pair of long faces, poled in thickness and vibrating in the longitudinal dimension. Since these coefficients are energy ratios, they are dimensionless.

#### 4.3.7 Young's Modulus:

The mechanical stiffness property of a piezoelectric ceramic material is expressed as the ratio of stress to strain. Because mechanical stressing of the ceramic produces an electrical response which opposes the resultant strain, the effective Young's modulus with electrodes short circuited is lower than the electrodes open circuited. Furthermore, the stiffness is different in the 3 -direction from that in the 1 or 2 direction. Therefore, in expressing mechanical quantities both direction and electrical conditions must be specified.

$Y_{33}^D$  is the equivalent with the electrodes open circuited in the 3 direction whereas  $Y_{11}^D$  the modulus in the 1 or 2 direction. The superscript D points out the open circuit condition. The inverse of Young's modulus Y is the elastic compliance 's'.

#### 4.3.8 Dissipation Factor or $\tan \delta$ :

This is also frequently called loss tangent and is a measure of the dielectric losses in the material, expressed as the tangent of the loss angle or the ratio of resistance to reactance of a parallel equivalent circuit of the ceramic element. It is measured directly at 1 kHz using LCR Bridge.

#### 4.3.9 Curie Point:

It is the temperature at which the crystal structure of the material changes from a piezoelectric to non-piezoelectric state. It is also the temperature at which the dielectric constant peaks. Each ceramic composition has its characteristic Curie Point and in use the operating temperature must be kept substantially below the Curie Point.

#### 4.3.10 Aging Rate:

The change or aging of the material parameters that occurs after the poling of the ceramic is called aging rate. The aging is a logarithmic function of time. The aging rate defines change in the relevant parameters per decade of time, for example 1 - 10 days, 10 -100 days etc. The most parameters that age with time are:  $K_{33}^T$ ,  $k_p$ , Freq. constant,  $Q_{rn}$ , etc.

#### 4.3.11 Mechanical Quality Factor ( $Q_m$ ) :

The mechanical Q is a dimensionless number which gives the quality of the ceramic as a harmonic oscillator. It is the reciprocal of the damping factor. The electrical analogue (in an equivalent electric series circuit, representing the mechanical vibrating resonance system) is the ratio of reactance to resistance. The shape of the part affects the value.

#### 4.3.12 Frequency Constants:

The frequency constant,  $N$ , is the product of the resonance frequency and the linear dimension governing the resonance. It is also equal to half the sound velocity in the same direction. The constant can be used to calculate the resonant frequency at which an element would operate.

$N_p$  : Planar mode of thin disc

$N_t$  : Thickness mode of thin plate

To calculate the resonant frequency of a given element in kHz, divide the frequency constant by the controlling dimensions as shown below.

$f_r = \text{Frequency Constant (Hz-m)} / \text{Dim. (L, T, D) in m.}$

Table 4.2 presents the piezoelectric properties measured 24 hours after poling for piezo patches presently used in the investigation.

SP-5A & SP-5H material properties have been used in the FE models for carrying out the theoretical analysis of the specimen under investigation.

Table 4.2  
PIEZOELECTRIC PROPERTIES #

DATA	Lead Zirconate Titanate					Lead Titanate
	SP-4	SP-8	SP-5A	SP-5J	SP-5H	SP-2
Piezoelectric Coupling Co-efficient: K <sub>p</sub> K <sub>33</sub>	0.60 0.68	0.50 0.63	0.61 0.70	0.63 0.71	0.63 0.73	0.01 0.52
Piezoelectric Charge Constants D <sub>33</sub> (x 10 <sup>-12</sup> C/N) D <sub>31</sub> (x 10 <sup>-12</sup> C/N)	300 -122	215 -97	400 -170	460 -195	550 -247	68 -3
G (X 10 <sup>-3</sup> V m/N) G (X 10 <sup>-3</sup> V m/N)	27 -11	24 -11	26 -11	22 -9	20 -9	39 -1.7
Relative dielectric Constant, K <sub>3</sub> <sup>T</sup> (low signal)	1250	1000	1750	2450	3100	195
Dissipation factor, tan δ (low field)	0.004	0.004	0.020	0.020	0.020	0.010
Density, ρ (kg/m <sup>3</sup> )	7600	7600	7650	7500	7500	6900
Curie Temperature, T <sub>c</sub> (°C)	325	330	360	260	190	200
Mechanical Quality Factor, Q <sub>m</sub>	500	1000	75	70	65	-
Figure of Merit d <sub>h</sub> x g <sub>h</sub> (x 10 <sup>-15</sup> )	150	110	65	150	07	2400
Elastic Constants, short circuit S <sub>11</sub> <sup>E</sup> (X10 <sup>-12</sup> m <sup>2</sup> /N) S <sub>33</sub> <sup>E</sup> (X10 <sup>-12</sup> m <sup>2</sup> /N)	12 18	12 13	16 21	14 19	15 21	- -
Frequency Constants (Hz-m) N <sub>p</sub> (planar mode disk) N <sub>t</sub> (thickness mode disk)	2200 1905	2270 2032	1950 1800	2000 1950	1950 2000	- 2200
Ageing Rate, % change per time decade K <sub>3</sub> <sup>T</sup> K <sub>p</sub> N <sub>p</sub>	-2.5 +1.6 +1.0	-4.6 -2.0 +0.8	-0.1 -0.7 +0.1	-0.4 -1.5 +0.2	-0.4 -0.9 +0.15	-0.3 - +0.3

(Normal Characteristics measured 24 hours after poling at room temperature)

# Data available online at <http://www.sparklceramics.com>

(Relevant Web page addresses are given before Appendices)

In gist, the constitutive electro-mechanical equations of piezo materials as mentioned in Chapter 3 are summarized with different nomenclature ( not compatible with the nomenclature used in the chapter ) just for clarity as follows with all the units of the constants properly annotated in Fig 4.7 [183] and [184] :

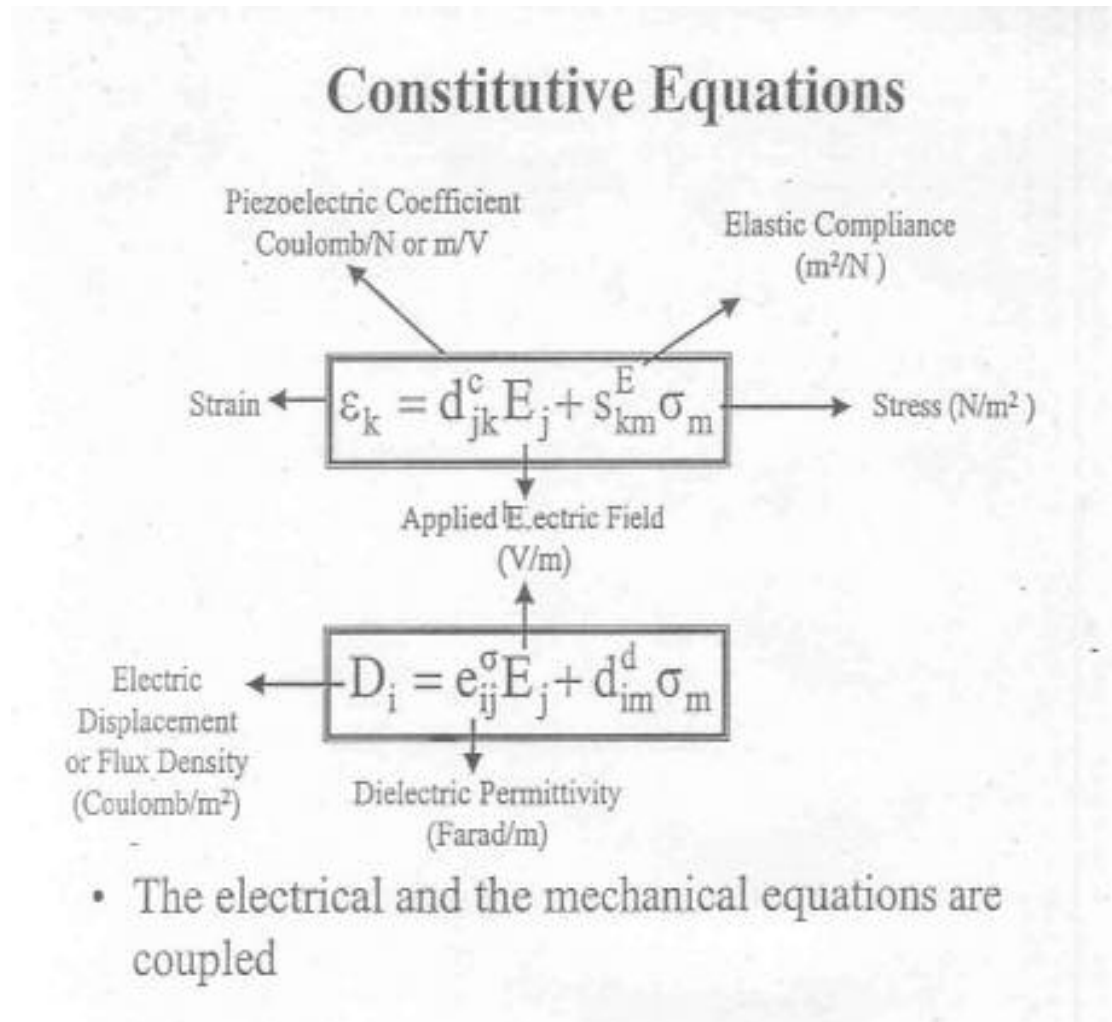

Fig. 4.7: Constitutive Equations

#### 4.4 Calculations of values for coupling coefficients

Following is the compilation of the terminology used in the domain of piezoelectric materials as explained in article 4.3 in detail. Here the details are presented w.r.t how their respective values are obtained by the manufacturer of the piezo crystals:

S. No.	Term	Description
1	$k_{33}, k_{31}, k_p$	Piezoelectric Coupling Factors
2	$K_3^T$	Free Relative Dielectric Constant
3	D or $\tan \delta$	Dissipation factor
4	$s_{33}^D, s_{11}^D, s_{11}^E, s_{33}^E$	Elastic Constants
5	$d_{33}, d_{31}$	Piezoelectric Charge Constants
6	$g_{33}, g_{31}$	Piezoelectric Voltage Constants
7	$Q_m$	Mechanical Quality Factor
8	$f_m$	Frequency of minimum impedance or resonance frequency
9	$f_n$	Frequency of maximum impedance or anti-resonance frequency
10	$Z_m$	Impedance at resonance frequency or frequency of minimum impedance

Various constants obtained by the manufacturer are as follows:

- Density: The density in kilograms/meter<sup>3</sup> is required in later calculations.

$$\text{Density} = \text{weight in kilograms} / \text{volume in meter}^3$$

$$\text{or } \rho = \frac{(\text{weight in air in kilograms})}{\text{Weight in air} - \text{weight in water}} \times 10^3 \text{ in kg.}$$

- Free Relative Dielectric Constant  $K_3^T$ :

This is calculated from the measured values of capacitance and physical dimensions of the specimen.

$$K_3^T = \frac{\text{distance between electrodes (meters)} \times C(\text{pF})}{\text{area of one electrode (meter}^2) \times 8.85}$$

- The dissipation factor is determined while measuring capacitance. No calculation is necessary.

- Coupling:

Coupling is calculated from the frequencies of minimum and maximum impedance. The applicable formula depends on the vibration mode as shown below. The frequencies of minimum and maximum impedance are not the exact frequencies

required for these calculations, and a small correction theoretically should be made as described in the IRE Standards. However, when dealing with barium titanate and lead Zirconate-Lead Titanate compositions, the error resulting from omitting the correction is not significant. Accordingly, the corrections generally are not made.

- Coupling  $k_{33}$ :

This is applicable only to length-poled rods as shown in Fig. 4.8

$$k_{33} = \Lambda = \frac{\pi \cdot f_n}{2 \cdot f_m} \tan \left[ \frac{\pi}{2} \frac{(f_n - f_m)}{f_m} \right]$$

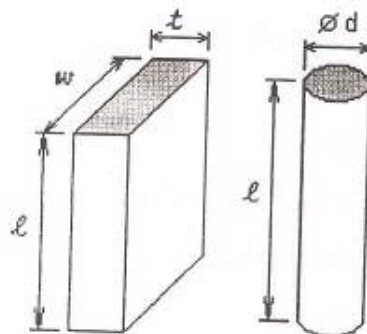

Fig.4.8: Both ends fully electroded (rods)

Curve of Fig. 4.9 is used to determine  $k_{33}$ .

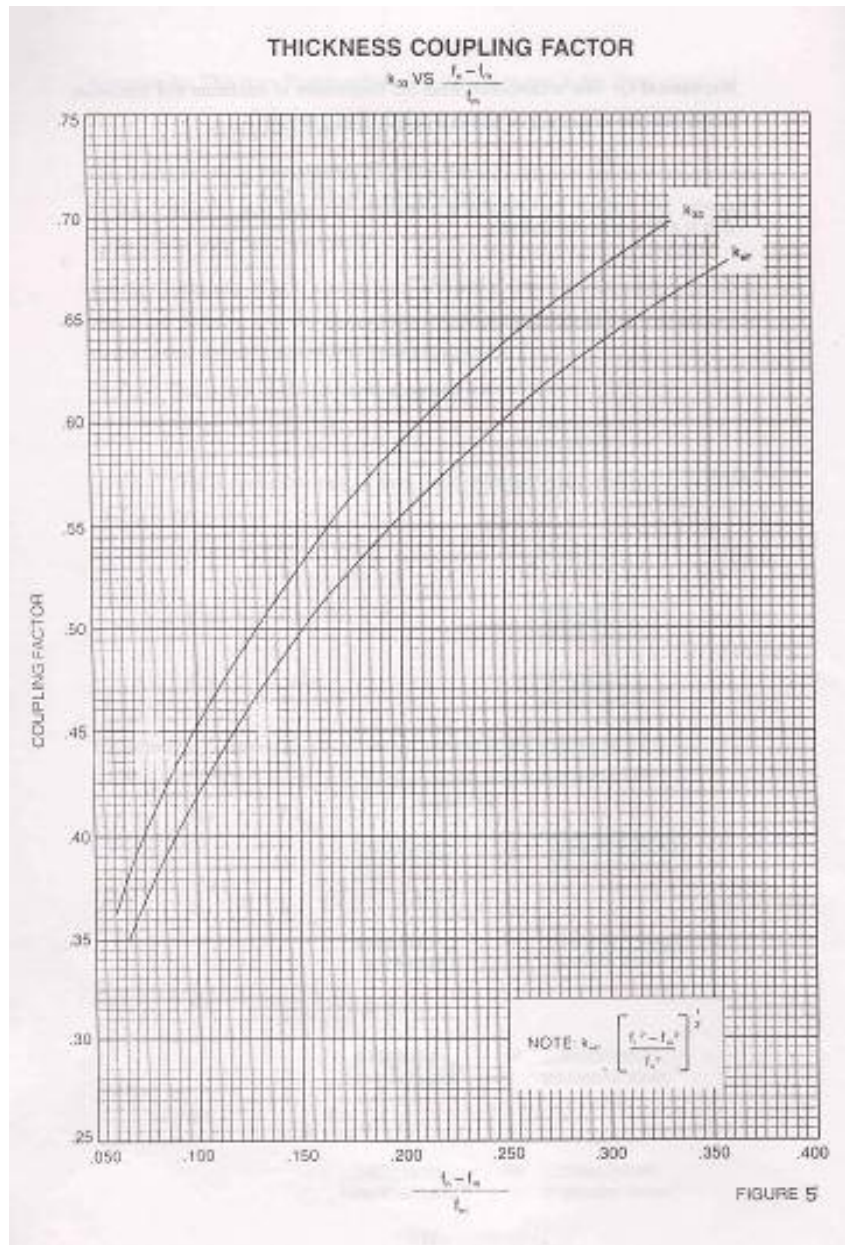

Fig. 4.9: Thickness Coupling Factor

- Coupling  $k_{31}$ :

This is applicable only to long, slim, thickness-poled specimens as shown in Fig 4.10.

$$A = \frac{\pi f_n}{2 f_m} \tan \left[ \frac{\pi (f_n - f_m)}{2 f_m} \right]$$

Curve of Fig 4.11 is used to determine  $K_{31}$ .

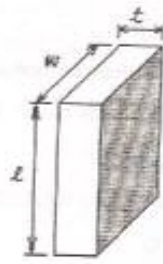

Fig. 4.10: Major faces fully electroded (plates)

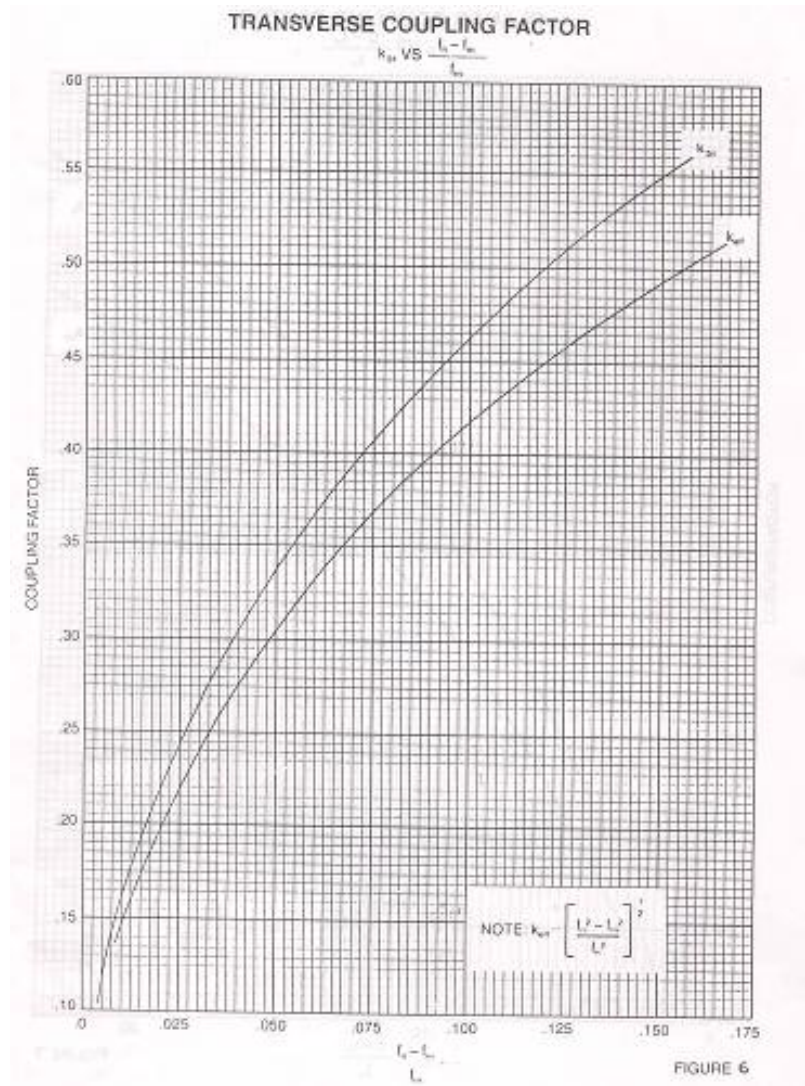

Fig. 4.11: Transverse coupling factor

- Coupling  $k_p$ :

This is applicable only to thin discs as shown in Fig. 4.12

$$\text{Calculate : } \frac{f_n - f_m}{f_m}$$

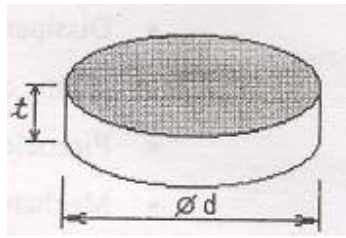

Fig. 4.12: Major faces fully Electroded (discs)

Curve of Fig 4.13 is used to determine  $k_p$ . Fig. 4.13 is valid only for piezoelectric ceramic having Poisson's ratio near 0.3. Presently available lead titanate-lead zirconate compositions meet this requirement.

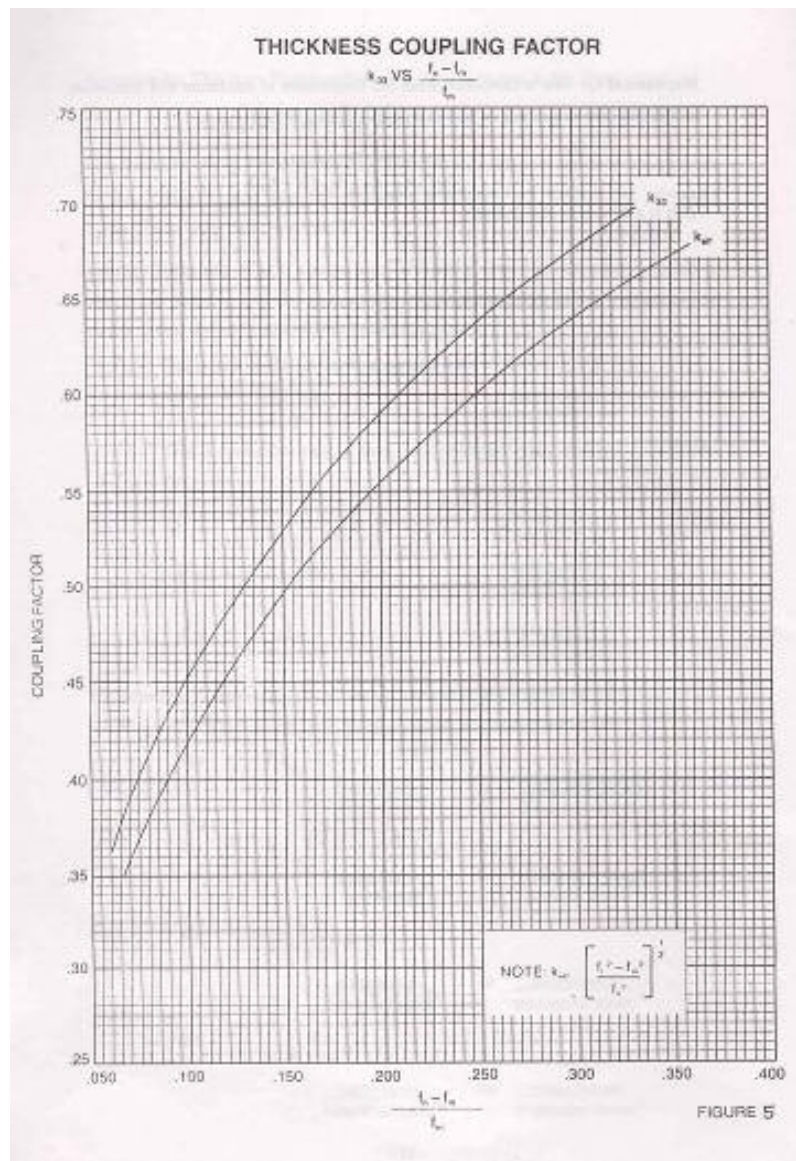

Fig 4.13 Planar coupling factor

- Elastic Constants:

Elastic constants are calculated from the frequency controlling dimension, density, and the frequencies of minimum or maximum impedance as shown below. Physical dimensions must be in meters.

$S_{33}^D$ . This is applicable only to length poled rods as shown in Fig. 4.8.

$$S_{33}^D = \frac{1}{4 \cdot \rho \cdot f n^2 \cdot l^2} \quad \frac{\text{meter/meter}}{\text{Newton/meter}^2}$$

$S_{11}^E$ . This is applicable only to long, slim thickness-poled specimens as shown in Fig. 4.10

$$S_{11}^E = \frac{1}{4 \cdot \rho \cdot f n^2 \cdot l^2} \quad \frac{\text{meter/meter}}{\text{Newton/meter}^2}$$

$$S_{33}^D = (1 - k_{31}^2) \cdot S_{11}^E \quad \frac{\text{meter/meter}}{\text{Newton/meter}^2}$$

- Piezoelectric Constants:

The d and g constants are calculated from values of coupling, dielectric constant, and elastic constant previously calculated.

$$d_{33} = k_{33} \sqrt{8.85 \times 10^{-12} \text{ K}_3^T \cdot S_{33}^E}$$

$$\frac{\text{meter/meter}}{\text{volt/meter}} \quad \text{or} \quad \frac{\text{coulombs/meter}^2}{\text{Newton/meter}^2}$$

$$d_{31} = k_{31} \sqrt{8.85 \times 10^{-12} \text{ K}_3^T \cdot S_{33}^E}$$

$$\frac{\text{meter/meter}}{\text{volt / meter}} \quad \text{or} \quad \frac{\text{coulombs/meter}^2}{\text{Newton / meter}^2}$$

$$g_{33} = \frac{d_{33}}{8.85 \times 10^{-12} \text{ K}_3^T}$$

$$\frac{\text{Volts/meter}}{\text{Newtons/meter}^2} \quad \text{or} \quad \frac{\text{meter/meter}}{\text{coulombs/meter}^2}$$

$$g_{31} = \frac{d_{31}}{8.85 \times 10^{-12} \text{ K}_3^T}$$

$$\frac{\text{Volts/meter}}{\text{Newtons/meter}^2} \quad \text{or} \quad \frac{\text{meter/meter}}{\text{coulombs/meter}^2}$$

- Mechanical Q:

This is calculated from the frequencies of minimum and maximum impedance, the magnitude of minimum impedance and capacitance.

$$Q_m = \frac{f_m^2}{2\pi \cdot f_m \cdot Z_m \cdot C \cdot (f_n^2 - f_m^2)}$$

This is a dimensionless quantity.

#### 4.5 Vibrational Modes in Common Transducer Configurations

Different shapes are capable of different modes of vibration -each having a natural resonant frequency corresponding to the minimum impedance condition and each characterised by a frequency constant as previously discussed. The various modes of vibration in the transducers are shown below:









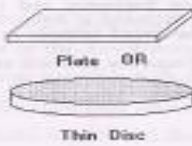
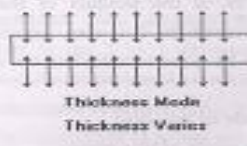

SHAPE AND ELECTRODE POSITION	MODE AND PRIMARY MOTION	DIRECTION OF POLARISATION
 <p>Plate OR Thin Disc</p>	 <p>Thickness Mode Thickness Varies</p>	
 <p>Thin Disc</p>	 <p>Radial Mode - Radius Varies</p>	
 <p>Thin Walled Tube</p>	 <p>Radial Mode - Radius Varies</p>	
 <p>Ring</p>	 <p>Thickness Mode - Thickness Varies</p>	
 <p>Ring</p>	 <p>Radial Mode - Radius Varies</p>	

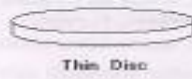
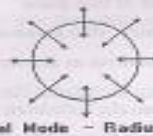
Fig 4.14 : Various modes of vibration in the transducers

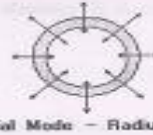
The actual in-plane Force,  $F$  in Newton (N) exerted by the patch on the substrate can be estimated using the given input value of DC Voltage ( $V$ ) for the chosen piezo patch,  $g_{33}$  value in Vm per N of the patch, thickness of the patch in meter (m) and area of patch in  $m^2$  for the given type of patch as follows:

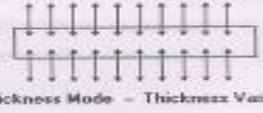
$$\text{Voltage} = [ F \times g_{33} \times (\text{thickness}) \text{ of patch } ] / [ \text{Area of the patch } ]$$

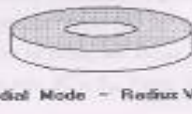
For theoretical simulation of the forces on the reflector by this approach has been used in Chapter 8 of the thesis.

The rods, disc type of piezo crystals have not been used in the present investigation on composite reflectors . Only flat piezo patches have been put in to practice because of the adhesion requirements of the patches for proper strain transfer on the skin of the reflector particularly with patches envisaged on the convex side of the reflector. Patches cannot be mounted on the concave side because the electromagnetic signals striking the concave side of the parabolic reflectors in the transmit and receive mode. Moreover, in case of piezo patches, percentage coverage also plays a vital role as explained in Chapter 8. However, it is worth mentioning here, that in the absence of curved patches in Indian market, only small size flat patches have been used in the preliminary investigation of shape deformation studies of doubly curved parabolic reconfigurable reflectors envisaged for INSAT / GEOSAT spacecraft reflectors.

As against this, it is relevant to mention here that as mentioned in the Chapter 2 ,the actual shape studies work carried out on small size parabolic reflectors made up of metalized Lexan at Ohio sate University USA, has been carried out using curved Thunder Actuators. As the proposed study is planned by using presently available Indian product of flat piezo patches , it has been called a preliminary investigation and use of actual curved patches designed as per the radius of curvature of reflector for better strain transfer are proposed in future scope of work.

Keeping in view all the points mentioned from Chapter 1 to Chapter 4, the details of the main investigation for case 1 & case 2 are now presented from Chapters 5 to Chapters 8 of thesis.

\*\*\*\*\*